

MELLOTT[®]

TECHNICAL DATA – MC120P



VIBRATING GRIZZLY FEEDER

- Metso HR 46"x20' Vibrating Feeder
- 40 HP, 1800 RPM, TEFC Electric Motor
- 14' Pan w/ Replaceable ¾" AR Liners
- 6' Grizzly Section w/ Adjustable Bars @ 4" Openings

JAW CRUSHER

- Metso C120 Jaw w/ Integral Motor-Mount
- Feed Opening 47"(W)x34"(D)
- 200 HP Crusher Duty Motor 1200 RPM, TEFC
- Closed Side Setting 2¾"– 8"
- Composite Guards, Crusher Feed Chute

CHASSIS

- Heavy Duty Fabricated Frame Complete w/ Cribbing Supports
- Triple-Axle Suspension with Twelve (12) 11R24.5 Tires
- Road Ready (Air Brakes, Light Kit, Mud Flaps)

UNDER CRUSHER CONVEYOR

- 20 HP, 48"(W)x35'(L) Conveyor
- Channel Frame Construction
- CEMA C5 Idlers
- Rubber Impact Bed @ Load Zone

AVAILABLE OPTIONS

- Hydraulic Breaker and Support Structure
- Control House
- Pre-Wired Electrical Starter Panel
- Additional Hopper Capacity up to 39 Cubic Yards
- Hydraulic Leveling Legs w/ Power Pack

MELLOTT®

TECHNICAL DATA – MC120P

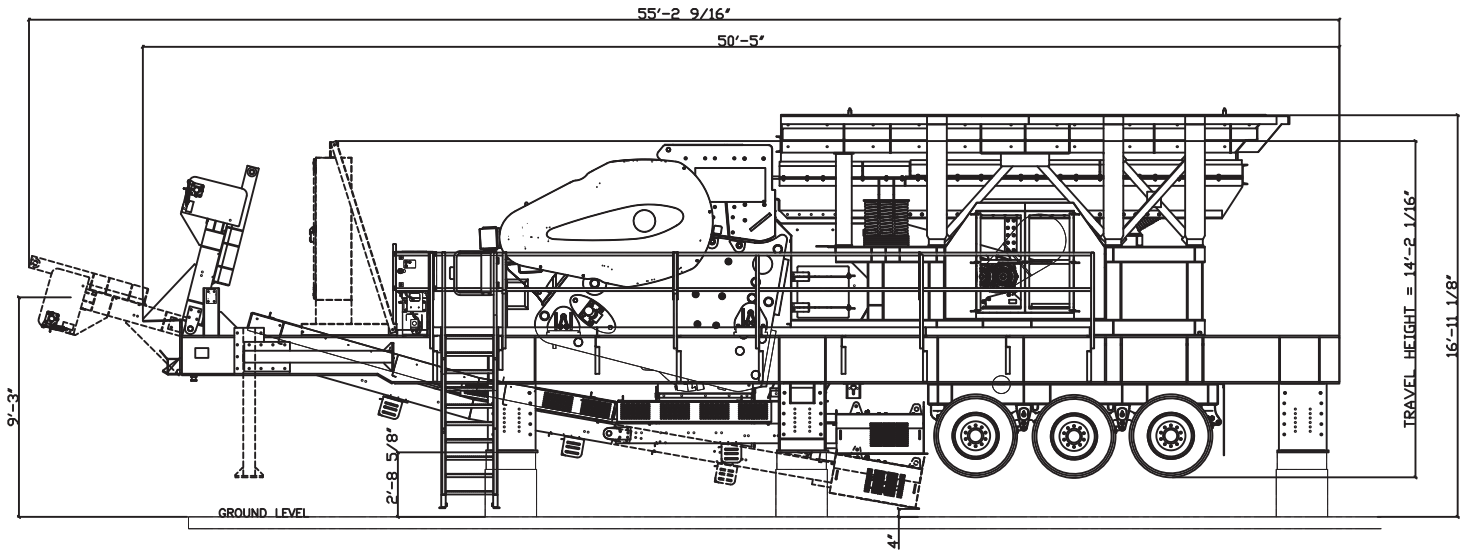

Basic Model Shown

* - Travel height does not include feeder stand. Feeder stand to ship separate.

CRUSHER

- Max Feed Size..... 27"
- Maximum Plant Capacity.....600 STPH

PHYSICAL/OPERATING CHARACTERISTICS

- Overall Length.....55'-9"
- Overall Height..... 16'-11½"
- Travel Height..... 14'-2"
- Ground Clearance..... 5½"
- Travel Width..... 11'-10"
- Feed Height..... 16'-11½"
- Discharge Height..... 9'-2"
- Trailer 1 Weight..... 102,200 Lbs

Total Unit Weight.....139,451 Lbs

Specifications are subject to change without notice.

Model MC120P 032024

MAIN OFFICE
100 MELLOTT DRIVE
WARFORDSBURG, PA 17267

SOUTHERN SERVICE CENTER
169 MACHINE SHOP ROAD
MARION, NC 28752

CUSTOMER SERVICE HOTLINE: 800-634-5634 ■ EMAIL: SALES@MELLOTTSCOM

VISIT US @ WWW.MELLOTTCOMPANY.COM